

ТЕХНОЛОГІЯ ЛЕГКОЇ ТА ХАРЧОВОЇ ПРОМИСЛОВОСТІ

УДК 677.11.021

<https://doi.org/10.35546/kntu2078-4481.2023.3.8>

A. Y. LYSYKH

Candidate of Technical Sciences,
Senior Lecturer at the Department of Energy Engineering
Pervomaisky Educational and Scientific Institute
of National University of Shipbuilding
named after Admiral Makarov
ORCID: 0000-0002-0979-7736

S. M. KOBYAKOV

Candidate of Agricultural Sciences, Associate Professor,
Associate Professor at the Department of Commodity Science,
Standardization and Certification
Kherson National Technical University
ORCID: 0000-0002-2811-7572

ANALYSIS OF THE USE OF MECHANICAL PROCESSING EQUIPMENT IN THE PROCESS OF OBTAINING TEXTILE RAW MATERIALS

The production of the same type of fiber involves the processing of raw linen with the aim of removing the fiber from it with maximum cleaning of it from fire and other non-fibrous impurities with minimal damage. The article analyzes the theoretical prerequisites for obtaining the same type of fiber with the use of various aggregates during the mechanical processing of material stalks. In order to improve the processing conditions of the stems in the milling part of the unit, the raw materials must first be parallelized with the location of the layer elements in the axial direction of the unit. Parallelization of the stems is achieved by extracting a layer of the processed material due to the difference in the linear speeds of the grinding pairs; at the same time, the speed of material movement in each subsequent grinding pair is greater than in the previous one.

The layer of material pre-washed in the grinding part of the unit enters the tripping part. From the last grinding pair, the layer enters the feed unit, which feeds the material to the triple drum. The working organs of the triple drum are the radially arranged hammer bars and combs.

When using corrugated rollers, the stems follow the path of a broken line. When processing fiber on shaking machines with an upper comb field and a needle conveyor, the speed of movement of the material in the shaking part of it is determined by the angle of advance, the amount of shaking needles between the conveyor needles and the speed of the conveyor.

When the triple drum rotates at a high speed, the impact bars and combs alternately affect the layer of the material being processed, and due to the change in the direction of the relative speed, the absolute speed of the layer elements changes under the action of the bar and combs. It has been established that in order to enhance the crushing process, the upper rollers are rotated from the lower rollers due to the friction of the grooves through the layer of the processed material, and not with the help of gears.

The efficiency of the shaking machines depends on a number of factors, which include the speed of material advancement in the comb field, the number of swings of the comb roller needles per unit of time, the density of the material loading, the advance angle, the swing of the needles and the position of the grid in relation to the tips of the needles. When the depth of penetration of the grooves increases, the pressure on the layer of the processed material increases.

The expediency of using planar-type milling rollers in the process of obtaining the same type of flax fiber with a gradual increase in their circumferential speed in the direction of material movement, which ensures the sliding of the material relative to the edge of the groove of the roller, and ensures the intensification of the process of breaking the bond between the fiber and the wood of the stem, is substantiated.

Key words: single-type fiber, chaff, crushing process, shaking process, scutching drum.

А. Ю. ЛИСИХ

кандидат технічних наук,
старший викладач кафедри енергетичного машинобудування
Первомайський навчально-науковий інститут
Національного університету кораблебудування
імені адмірала Макарова
ORCID: 0000-0002-0979-7736

С. М. КОБ'ЯКОВ

кандидат сільськогосподарських наук, доцент,
доцент кафедри товарознавства, стандартизації та сертифікації
Херсонський національний технічний університет
ORCID: 0000-0002-2811-7572

АНАЛІЗ ВИКОРИСТАННЯ МЕХАНООБРОБНОГО ОБЛАДНАННЯ В ПРОЦЕСІ ОТРИМАННЯ ТЕКСТИЛЬНОЇ СИРОВИНИ

Виробництво однотипного волокна передбачає переробку лляної сировини з метою видалення з неї волокна з максимальним очищенням його від багаття та інших неволокнистих домішок при мінімальних ушкодженнях. У статті проведено аналіз теоретичних передумов отримання однотипного волокна з застосуванням різних агрегатів під час механічної обробки стебел матеріалу. Для покращення умов обробки стебел у м'яльній частині агрегату, сировину попередньо необхідно паралелізувати з розташуванням елементів шару в осьовому напрямку агрегату. Паралелізація стебел досягається витяжкою шару оброблюваного матеріалу за рахунок різниці лінійних швидкостей м'яльних пар; при цьому швидкість руху матеріалу в кожній подальшій м'яльній парі більша, ніж у попередній.

Попередньо пром'ятий у м'яльній частині агрегату шар матеріалу надходить до тріпального частини. З останньої м'яльної пари шар надходить до вузла живлення, що подає матеріал до тріпального барабана. Робочими органами тріпального барабана є радіально розташовані бильні планки та гребені.

При обертанні тріпального барабана з великою швидкістю бильні планки і гребені по чергово впливають на шар матеріалу, що обробляється, і за рахунок зміни напрямку відносної швидкості відбувається зміна абсолютної швидкості елементів шару при дії планки і гребенів. При збільшенні глибини заходження рифлів підвищується тиск на шар матеріалу, що обробляється.

При використанні рифлених вальців стебла проходять шлях ламаної лінії. При обробці волокна на трясильних машинах з верхнім гребневим полем і голчастим транспортером, швидкість руху матеріалу в трясильній частині його визначається кутом випередження, величини заходження трясильних голок між голками транспортера та швидкістю транспортера.

Встановлено, що для посилення процесу м'яття верхні вальці приводяться в обертання від нижніх вальців завдяки зчепленню рифлів через шар оброблюваного матеріалу, а не за допомогою шестерень.

Ефективність роботи трясильних машин залежить від ряду факторів, до яких належать швидкість просування матеріалу в гребневому полі, кількість хитань голок гребневих валиків за одиницю часу, щільність завантаження матеріалу, кут випередження, розмах голок та положення решітки щодо кінчиків голок.

Обґрунтовано доцільність використання у процесі отримання однотипного волокна льону м'яльних вальців планчастого типу з поступовим збільшенням їх окружної швидкості у напрямку руху матеріалу, що забезпечує ковзання матеріалу щодо кромки рифля вальця, та забезпечує інтенсифікацію процесу руйнування зв'язку між волокном та деревиною стебла.

Ключові слова: однотипна сировина, костриця, процес м'яття, процес тіпання-чесання, процес трясіння.

Formulation of the problem

The short fiber produced in modern flax mills is a by-product because the long fiber is more important. In this regard, the processes of harvesting flax and preparing flax require a special set of machines, which have their own specifics, aimed at maximally preserving the parallelism of the stalks and their minimal stretching behind the comb. The low productivity of harvesting equipment, high fuel losses and energy consumption lead to a high production cost [1, 9].

The use of flax fiber in secondary and advanced processing has changed significantly. Today, short flax fiber is widely used in the textile industry in a mixture with other natural and chemical fibers, for the production of textile products, modern composite materials, for cotton wool, insulation and for other purposes.

Analysis of recent research and publications

In literary sources, we find information about changes in the technologies of collecting and obtaining fiber, which are primarily aimed at saving resources. Thus, when harvesting flax, adapted, high-performance agricultural machines of general purpose are used: harvesters, combine harvesters, roll turners, roller presses and other equipment. The use of such equipment allows you to fully mechanize the processes of collecting and processing raw materials, and significantly reduce material and energy costs. One more positive feature of this technology should also be noted, for example, harvesters are used during harvesting, which cut the stalks at a height of 5–7 cm from the soil surface, leaving low-quality fiber in the field, and in this way, the overall quality of the fiber obtained from the trust increases. Taking into account the above, it is relevant to obtain flax fiber from flax in the form of short (uniform) with low cost [2, 8].

Many different methods and devices are known for the production of the same type of fiber. A characteristic feature of them is that these units are designed for the processing of the wastes of the tap and are not adapted for the direct processing of the stems of the trust. These units consist of a large number of machines and mechanisms. At the same time, the stability of the implementation of the technological process is determined by the reliability of the component parts of the units.

Based on the above, the task of creating a unit for processing linen trust with a chaotic arrangement of stems in the mass arises. It should include a minimum number of highly effective mechanical actions on flax stalks while ensuring effective fiber cleaning from pith and other non-fibrous tissues [7, 10].

Setting of the task

The production of the same type of fiber involves the processing of raw linen with the aim of extracting fiber from it with the maximum possible cleaning of it from lint and other non-fibrous impurities with minimal damage. Flax fiber is very diverse in its properties, the raw material contains stems of different lengths, there are short stems no more than 300 mm long, and long ones – more than 1000 mm [6, 10].

The strength and stiffness of the fiber contained in the raw material also depends on the properties of the trust being processed. Due to the significant heterogeneity of the initial material used for the preparation of short fiber, its processing is very time-consuming. It is practically very difficult to increase the homogeneity of the physical properties of such material by sorting, besides, sorting is an economically impractical technological operation, since the costs for it do not justify themselves.

It becomes necessary to investigate the next technological process – the technology of obtaining the same type of flax fiber from non-oriented stems of the flax plant [7].

Presenting main material

Obtaining the same type of fiber from the trust involves the processing of dried raw materials on technological equipment (crushing, pounding, shaking).

Consider the crushing process. It is known that the initial raw material for obtaining the same type of fiber is very heterogeneous. At the same time, it has a chaotic arrangement of stems in a layer relative to the axis line of the unit. Thus, cases are possible when individual stalks will be located parallel to the axial lines of the grinding rollers. Such stalks are not subject to processing, as a result of which the technological effect of the further processing process (tumbling and shaking) is significantly reduced. To improve the processing conditions of the stems in the milling part of the unit, the raw materials must first be parallelized with the location of the layer elements in the axial direction of the unit.

To enhance the crushing process, the upper rollers are rotated from the lower rollers due to the friction of the grooves through the layer of processed material, and not with the help of gears. Depending on the depth of the grooves, the pressure on the layer of processed material increases. When using corrugated rollers, the stems follow the path of a broken line (Fig. 1). The length of the section of the stems, which is subject to bending in one rotation of the rollers, is called the perimeter of the fracture P_3 .

$$P_3 = Z \cdot t_{\text{п}}, \tag{1}$$

where P_3 – fracture perimeter, mm

Z – number of flutes of rollers;

$t_{\text{п}}$ – step of the trust, mm

Then the speed of movement of the material in a pair of rollers will be equal to:

$$v_{\text{п}} = \frac{n \cdot Z \cdot t_{\text{п}}}{1000}, \tag{2}$$

where n – rotation frequency of rollers, min^{-1} .

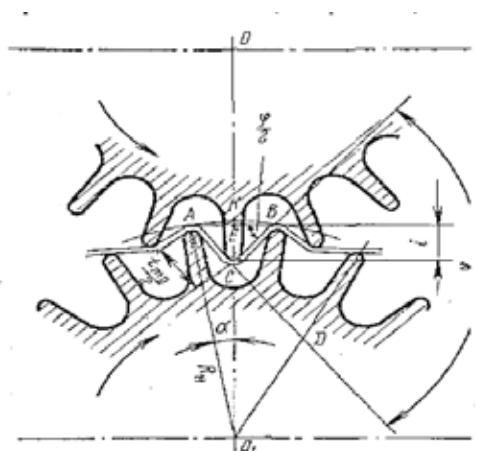
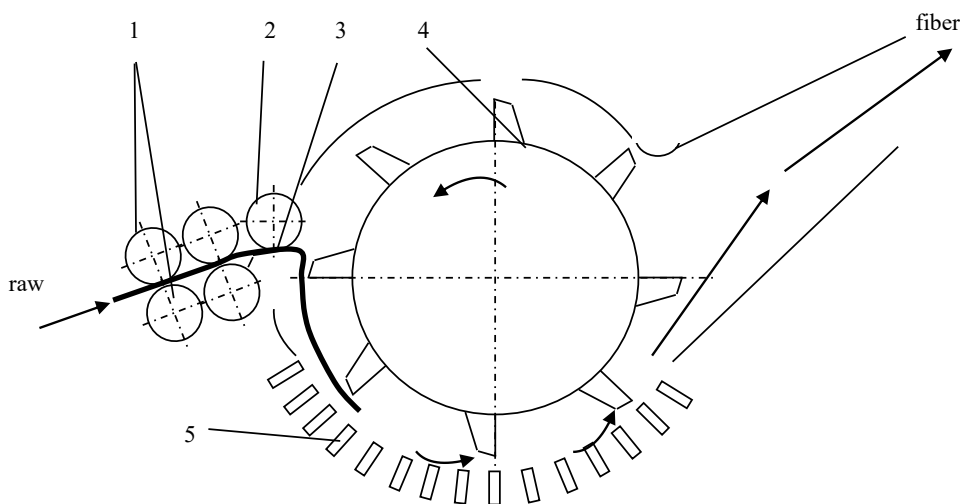

Fig. 1. Scheme of the interaction of the grooves of a pair of rollers and the stem

Source: [6]

The operating mode of the grinding part of the unit is set depending on the physical properties of the processed raw materials [4, 6]. Let's consider the process of stamping. The layer of material previously washed in the grinding part of the unit enters the heating part. From the last grinding pair, a layer of material enters the feeding unit, which feeds the material to the grinding drum. The working organs of the tupal drum are radially located hammer bars and ridges (Fig. 2).



1 – smooth rollers; 2 – feeding roller; 3 – feeding tray; 4 – combing drum; 5 – grill grate

Fig. 2. Technological diagram of the combing and combing part

Source: [6]

During the rotation of the tapping drum at high speed, the impact bars and combs alternately affect the layer of the processed material, and due to the change in the direction of the relative speed, there is a change in the absolute speed of the elements of the layer under the action of the bar and combs. Together with a change in the absolute speed of the strand elements at the moment of their interaction with the edge of the punch bar, there is a large acceleration of the elements of the material layer in the area resting on the edge.

The forces of inertia caused by these accelerations reach a significant value and change in proportion to the square of the speed of the working edges of the impact strips. Inertial forces, and together with them other forces (friction, pressure, tension) arising in the layer of material during tamping, ensure the removal of burrs and other non-fibrous impurities from the processed material.

The mode of operation of the heating part with a high throughput capacity of the unit should ensure a sufficiently high degree of cleaning of the fiber from the pile. The degree of cleaning of fiber from pits in the process of beating depends on the following factors: the frequency of rotation of the beating drum, the speed of feeding the layer of processed material by the feeding unit, the gap between the slats and the grate, the thickness and structure of the material layer, as well as the quality of the material passing through the milling machine [3, 4].

The number of actions on the processed material in the heating part of the unit depends on the time the layer element is in the heating zone. The path that an element of a layer of material passes through the treading zone is equal to the length of the section of the layer bent by the hammer bar. The residence time t of this area in the treading zone is equal to the time of movement of the material layer in the treading zone:

$$t = \frac{l}{V}, \tag{3}$$

where l – length of the bent section of the layer, m;

V – feed rate, m/min

During time t , the elements of the processed material layer receive k actions:

$$k = m \cdot n \cdot \frac{l}{V}, \tag{4}$$

where k – is the number of actions. pieces;

m – the number of percussion strips on the drum, pcs.;

n – drum rotation frequency, min.^{-1} .

The gap between the hammer bar and the grate in the tamping unit is an adjustable value. When it is reduced, the degree of fiber cleaning increases due to the increase in the bending angles of the layer along the slats of the grate, when it is increased, it is the opposite.

Then, for better processing, it is desirable that this zone be minimal. The intensity of processing the material layer also depends on the length of the fibers in the layer and the degree of their parallelization [5, 6].

Consider the shaking process. Shaking is used to clean short fiber from pith, which is carried out on shaking machines, as a result of which, by repeated shaking, the short fiber is freed from bulk pith and other non-fibrous impurities.

All existing shaking machines can be combined into two groups: machines with a lower comb field and machines with an upper comb field (Fig. 3).

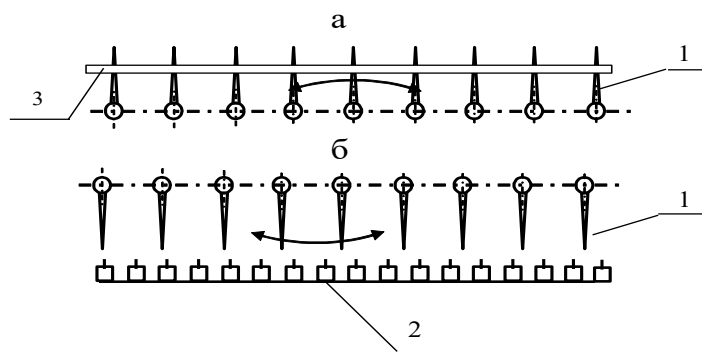

a) with the lower comb field; b) with the upper comb field

1 – needle ridges; 2 – needle conveyor; 3 – shaft

Fig. 3. Schematic diagrams of shaking machines

Source: [6]

Shaking machines with a lower comb field (Fig. 3, a) include those in which the needles point upwards. In machines with an upper comb field (Fig. 3, b), the tips of the needles are directed downwards. In addition, machines with an upper comb field differ in that they have needle conveyors 2, thanks to which the processed material receives additional movement. The needles of the comb field 1, located above the surface of the needle conveyor due to the difference in the speed of the conveyor and the swinging of the needles, provide partial removal of the pitting associated with the fiber, and also contribute to the parallelization and loosening of the fiber, while an increase in the intensity of actions is observed [6].

The fiber entering the deboning machine with the lower comb field is supported in the comb field on a special grid. The size of the gaps between the slats of the grid is such that the firewood falls freely down, and the fiber is retained on the grid. The grating in shaking machines with a lower comb field is located in an inclined plane, with a rise in the direction of the movement of the material. The centers of the axial lines of the comb shafts of shaking machines with the lower comb field are in one inclined plane at an angle of 6° to the horizontal plane.

In fig. 4 shows the diagram of the mutual location of the needles 1 of the comb shaft and the grid 2. The needles of the comb field, mounted on the comb shafts, receive an oscillating motion through the crank-rod mechanism. The tip of the needle has a different speed of movement, changing from zero at the extreme position of the needle (position of point A) and then from a maximum to zero at the extreme position of the needle along the movement of the material (position of point B).

Therefore, the speed of movement of the material on the grid will also be uneven, and this, in turn, causes the appearance of accelerations and inertial forces that act on the processed material. The inertial forces acting on the piece of fiber at the tip of the needle can be reduced to two forces: the centrifugal force and the force caused by tangential acceleration. Centrifugal force is directed along the needle from the swing axis to the top. The force caused by tangential acceleration (change in velocity in magnitude) is directed perpendicular to the needle. Centrifugal force reaches its greatest value in the case when the speed of movement of the needle is maximum. And the tangential force, on the contrary, has maximum values at the extreme positions of the needle.

When studying the forces of inertia, it is necessary to take into account the forces of gravity, under the influence of which the material tends to shift along the needle. Tangential forces during one revolution of the crank reverse their direction four times. These changes occur in a short period of time, which ensures a strong shaking of the material layer and the release of the core.

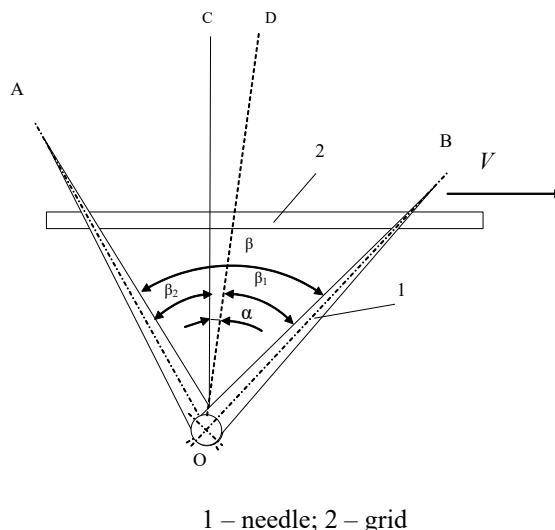

Fig. 4. Diagram of the mutual location of the needles of the shaft and the grid in a shaking machine

Source: [10]

When moving the needle from the extreme position against the movement of the material, the tangential acceleration changes from maximum to zero, and the needle in this area increases its speed from zero to maximum. At the same time, the needle creates a load on the material, which resists its movement, so the fiber loosens in this area. When the needle is further moved from the OD position to the extreme position in the direction of material movement (point B position), the tangential acceleration changes from zero to a maximum. The speed of the needle decreases from the maximum to zero, as a result of which the reverse phenomenon occurs – the needle resists the movement of the material. As a result of the action of these inertial forces, voids are formed, which facilitates the separation of the core from the fiber.

The forces that create a load on the material are proportional to the square of the speed of the needle and vary along the needle, increasing from the plane of the grid to the tip of the needle. These forces reach their maximum value at the tip of the needle. The speed of the needles is determined by the rotation frequency of the crank. The speed of movement of the material on the grid, regardless of the speed of the needle tip, varies depending on the angle of advance, the amount of departure of the needle in the extreme position in the direction of movement of the material, the radius of the crank, the thickness of the layer of the processed material and the moisture content of the material. The angle of advance is called the angle located between the perpendicular to the lattice and the bisector of the sweep angle. This angle at a constant position of the grid is adjusted using a connecting rod; as the length of the connecting rod increases, the advance angle increases, and vice versa. At the same time, the height of the tip of the needle in the extreme position in the direction of movement of the material relative to the lattice plane will change. The position of the tip of the needle relative to the grid plane can be adjusted by changing the position of the grid itself.

With an increase in the radius of the crank at a constant position of the grid, the speed of movement of the material increases, because the distance from the tip of the needle (in the extreme position of the needle in the direction of movement of the processed material) to the plane of the grid decreases. In the case when the needle pitch remains unchanged, the speed of the material decreases as the crank radius increases. This position is explained by the fact that with an increase in the radius of the crank, the circular speed of the needles increases and the time of free movement of the material on the grid decreases, as a result of which the needle quickly returns to the position from which the material started free movement.

When processing fiber on shaking machines with an upper comb field and a needle conveyor, the speed of movement of the material in the shaking part of it is determined by the advance angle, the amount of shaking needles between the conveyor needles and the speed of the conveyor [10]. The efficiency of shaking machines depends on a number of factors, which include the speed of the material in the comb field, the number of swings of the comb shaft needles per unit of time, the density of the material loading, the advance angle, the swing of the needles and the position of the grid relative to the tips of the needles.

Conclusions

On the basis of the combination of mechanical processes of crushing with sliding, stamping with combing and shaking, a resource-saving technology for extracting flax fiber from unoriented stalks of the plant without dividing the fiber into long and short is proposed.

Theoretically and experimentally, the expediency of using in the process of obtaining the same type of flax fiber, plate-type grinding rollers with a gradual increase in their circular speed in the direction of movement of the

processed material, which ensures the sliding of the material relative to the edge of the groove of the roller, which intensifies the process of breaking the bond between the fiber and wood stems. Reducing the pitch of the edges of the plate rollers and increasing the intersection between them ensures a gradual increase in the intensity of mechanical actions on the material.

Bibliography

1. Гілязетдінов Р.Н., Коротченко С.П., Москаленко Б.І. Нові процеси у виділенні волокна луб'яних культур. *Механізація та електрифікація сільського господарства*. 2010. № 94. С. 184-188.
2. Лисих А.Ю., Коб'яков С.М. Аналіз інноваційних технологій механічної переробки текстильної сировини. *Загальнодержавний міжвідомчий науково-технічний збірник. Конструювання, виробництво та експлуатація сільськогосподарських машин*. Кропивницький: ЦНТУ, 2020. Вип. 50. С. 164-172. DOI: <https://doi.org/10.32515/2414-3820.2020.50.164-172>.
3. Лисих А.Ю. Розробка та розрахунок кінематичної схеми механізму для одержання короткого льоноволокна. *Збірник наукових праць Кіровоградського національного технічного університету. Техніка в сільському господарському виробництві, галузеве машинобудування, автоматизація*. Кропивницький: КНТУ, 2018. Вип. 31. С. 21-28.
4. Круглий Д.Г., Клевцов К.М. Модель процесу дроблення технічних комплексів луб'яного волокна при механічних впливах. *Вестник Херсонського нац. технічного університету*. 2017. № 60 (1). С. 113-119.
5. Лисих А.Ю. Механічний процес підготовки сировини для одержання короткого лляного волокна. *Загальнодержавний міжвідомчий науково-технічний збірник. Конструювання, виробництво та експлуатація сільськогосподарських машин*. Кропивницький: ЦНТУ, 2017. Вип.47, ч.ІІ. С. 123-130.
6. Гілязетдінов Р.Н. Развитие научных основ створення інноваційних технологій первинної переробки луб'яних культур : дис. ... д-ра техн. наук: 05.18.01. Херсон, 2009. 329 с.
7. Березовський Ю.В. Застосування нових технічних рішень у виробництві лляної продукції. *Вісник ХНТУ*. 2014. № 4 (51). С. 51-58.
8. Богданова О.Ф., Березовский Ю.В. Современные технологии переработки составляющих льна для производства продукции различного назначения. *Материалы и технологии*. Витебск, 2018. № 2 (2). С. 9-13.
9. Березовський Ю.В. Використання нових технічних рішень у промисловому виробництві лляної продукції. *Наука та інновації*. Київ, 2016. Т. 12. Вип. 4. С. 53-70.
10. Березовський Ю.В. Напрямки модернізації обладнання переробки лляної сировини. *Вісник Хмельницького національного університету. Технічні науки*. Хмельницький, 2016. № 1 (233). С. 189-195.

References

1. Hiliazetdinov, R.N., Koropchenko, S.P., & Moskalenko B.I. (2010). Novi protsesy u vydilenni volokna lubianykh kultur [New processes in the extraction of bast crops]. *Mekhanizatsia ta elektrifikatsia silskoho hospodarstva*. – *Mechanization and electrification of agriculture*, 94, 184-188 [in Ukraine].
2. Lisikh A.Y., & Kobiakov S.M. (2020). Analiz inovatsiinykh tekhnolohii mekhanichnoi pererobky tekstylnoi syrovyny [Analysis of innovative technologies for mechanical processing of textile raw materials]. *Zahalnoderzhavnyi mizhvidomchyi naukovo-tekhnichnyi zbirnyk. Konstruyuvannia, vyrobnytstvo ta ekspluatatsiia silskohospodarskykh mashyn*. – *National interagency scientific and technical collection of work. Design, production and exploitation of agricultural machines*, Vol. 50, 164-172 [in Ukraine].
3. Lisikh A.Y. (2018). Rozrobka ta rozrakhunok kinematychnoi skhemy mekhanizmu dlia oderzhannia korotkoho lonovolokna [Development and calculation of the kinematic circuit of the mechanism for reception of a short flax fiber]. *Zbirnyk naukovykh prats Kirovohradskoho natsionalnogo tekhnichnogo univertsytetu. Tekhnika v silskohospodarskomu vyrobnytstvi, haluzeve mashynobuduvannia, avtomatyzatsiia*. – *Collected works of scientific works of Kirovohrad National Technical University. Machinery in agricultural production, industry machine building, automation*, Vol. 31, 21-28 [in Ukraine].
4. Kruhlyi D.H., & Klevtsov K.M. (2017) Model protsesu droblennia tekhnichnykh kompleksiv lubianoho volokna pry mekhanichnykh vplyvakh. [Model of the process of crushing technical complexes of bast fiber under mechanical influences]. *Vestnik Khersonskogo natsionalnogo tekhnicheskogo universytetu*. – *Bulletin of Kherson National Technical University*, Vol. 60, 1, 21-28 [in Ukraine].
5. Lisikh A.Y. (2017). Mekhanichnyi protses pidhotovky syrovyny dlia oderzhannia korotkoho llianohho volokna. [Analysis of innovative technologies for mechanical processing of textile raw materials]. *Zahalnoderzhavnyi mizhvidomchyi naukovo-tekhnichnyi zbirnyk. Konstruyuvannia, vyrobnytstvo ta ekspluatatsiia silskohospodarskykh mashyn*. – *National interagency scientific and technical collection of work. Design, production and exploitation of agricultural machines*, Vol.47, part II, 123-130 [in Ukraine].

6. Hiliazetdinov, R.N. (2009). Rozvytok naukovikh osnov stvorennia innovatsiinykh tekhnolohii pervinnoi pererobky lubianikh kultur [Development of scientific branches of bast crops primary processing]. *Extended abstract of Doctor's thesis*. Kheson [in Ukraine].
7. Berezovskyi Yu.V. (2014). Zastosuvannia novykh tekhnichnykh rishen u vyrobnytstvi llianoi produktsii. [Application of new technical solutions in the production of linen products]. *Visnyk KHNTU. – Bulletin of KhNTU*, Vol. 4, 51, 51-58 [in Ukraine].
8. Bohdanova O.F., & Berezovskyi Yu.V. (2018). Sovremennye tekhnolohii pererabotki sostavliaiushchikh lna dlia proizvodstva produktsii razlichnoho naznacheniiia. [Modern technologies for processing flax components for the production of products for various purposes]. *Materialy i tekhnolohii. – Materials and technologies*. Vitebsk. 2, 2, 9-13 [in Russian].
9. Berezovskyi Yu.V. (2016). Vykorystannia novykh tekhnichnykh rishen u promyslovomu vyrobnytstvi llianoi produktsii [The use of new technical solutions in the industrial production of linen products]. *Nauka ta innovatsii. – Science and innovation*. Kuiv, Vol. 12, 4, 53-70 [in Ukraine].
10. Berezovskyi Yu.V. (2016). Napriamky modernizatsii obladnannia pererobky llianoi syrovyny [Areas of modernization of linen processing equipment]. *Visnyk Khmelnytskoho natsionalnoho universytetu. Tekhnichni nauky. – Bulletin of Khmelnytsky National University. Technical sciences*. Khmelnytskyi, Vol. 1, 233, 189-195 [in Ukraine].